

FISHING AND PONTOON BOAT ANCHOR WINCH

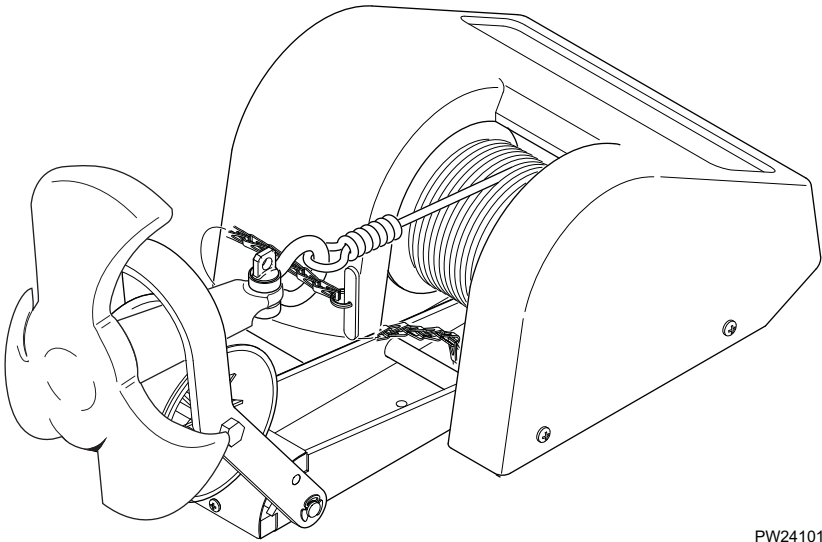

PW24101

The 24' Class anchor winch is a 12VDC power winch that retrieves and deploys river, mushroom, or navy type anchors using nylon rope.

These anchor winches feature power-in and power-out operation with a switch that can be mounted on the helm.

The 24' anchor winch has an integral roller davit.



Thoroughly read the manual furnished with this product and be familiar with the controls. Do not allow individuals to operate the winch without understanding the safe operation and procedures for the equipment.

PROPRIETARY STATEMENT

The *Powerwinch* Anchor Winch is a product of Carefree of Colorado, located in Broomfield, Colorado, USA. The information contained in or disclosed in this document is considered proprietary to Carefree of Colorado. Every effort has been made to ensure that the information presented in the document is accurate and complete. However, Carefree of Colorado assumes no liability for errors or for any damages that result from the use of this document.

The information contained in this manual pertains to the current configuration of the models listed on the title page. Earlier model configurations may differ from the information given. Carefree of Colorado reserves the right to cancel, change, alter or add any parts and assemblies, described in this manual, without prior notice.

Carefree of Colorado agrees to allow the reproduction of this document for use with Carefree of Colorado products only. Any other reproduction or translation of this document in whole or part is strictly prohibited without prior written approval from Carefree of Colorado.

TABLE OF CONTENTS

Safety Information	1
Specifications	2
Required Materials (not included with winch)	2
Mounting the Unit	3
Wiring the Unit	5
Testing the Unit	6
Loading the Rope	6
Attaching the Anchor	6
Operating the Winch	7
Safety Chain.....	7
Maintenance.....	7
Troubleshooting Guide	7
Replacement Parts List	8
Warranty	9

SAFETY INFORMATION

The following Safety Precautions Must be Followed at ALL Times. Failure to follow the warnings and cautions in this manual could result in serious injury and/or property damage.

 **WARNING** ALWAYS unplug the wiring harness before attempting to install, relocate, service or perform maintenance on the winch.

 **WARNING** NEVER use the winch to lift or move people or animals.

 **WARNING** NEVER use the winch for overhead lifting.

 **WARNING** NEVER attempt to pull a load greater than the rated load of the winch.

 **WARNING** NEVER use the winch to exclusively hold, support or permanently secure the load. Use separate straps to support the load.

 **WARNING** ALWAYS stand away from the winch during operation. ALWAYS stand clear of the area behind and between the load and the winch. Serious injury could occur if the rope breaks.

 **WARNING** NEVER wear loose fitting clothes, scarves, ties or jewelry when operating the winch. Loose clothing can become caught in moving parts.

 **WARNING** NEVER place foreign objects in the gypsy while retrieving or free falling the anchor. Serious injury can occur.

 **WARNING** ALWAYS tie off the anchor to a secure mount (e.g. a deck cleat) for storage and after lowering the anchor. NEVER use the winch to tie off the anchor.

 **WARNING** ALWAYS use the recommended rope and chain rode (a rode is a length of rope and chain).

 **CAUTION** ALWAYS keep hands clear of the cable spool (drum area).

 **CAUTION** ALWAYS wear leather gloves when handling the rope and chain.

CALIFORNIA PROPOSITION 65

 **WARNING** This product contains chemicals known to the state of California to cause cancer or birth defects or other reproductive harm. California's Proposition 65 requires this warning to be given to customers in the state of California.

SPECIFICATIONS

Anchor Weight	Line Speed (No Load)	Rope	Motor Voltage	Circuit Breaker	Unit Weight	Dimensions (L x W x D)
40 lbs. (max.)	80 ft/sec	3/16" x 100' Nylon	12VDC	15A	20 lbs.	10.5" x 6 x 9.25

REQUIRED MATERIALS (NOT INCLUDED WITH WINCH)

- Marine grade plywood for under deck support (optional).
- Loctite 242 thread locker or equivalent (optional).
- Silicone sealant.
- Navy, River or Mushroom style anchor up to a maximum weight of 40 lbs.
- Shackle to attach anchor to rope.

MOUNTING THE UNIT

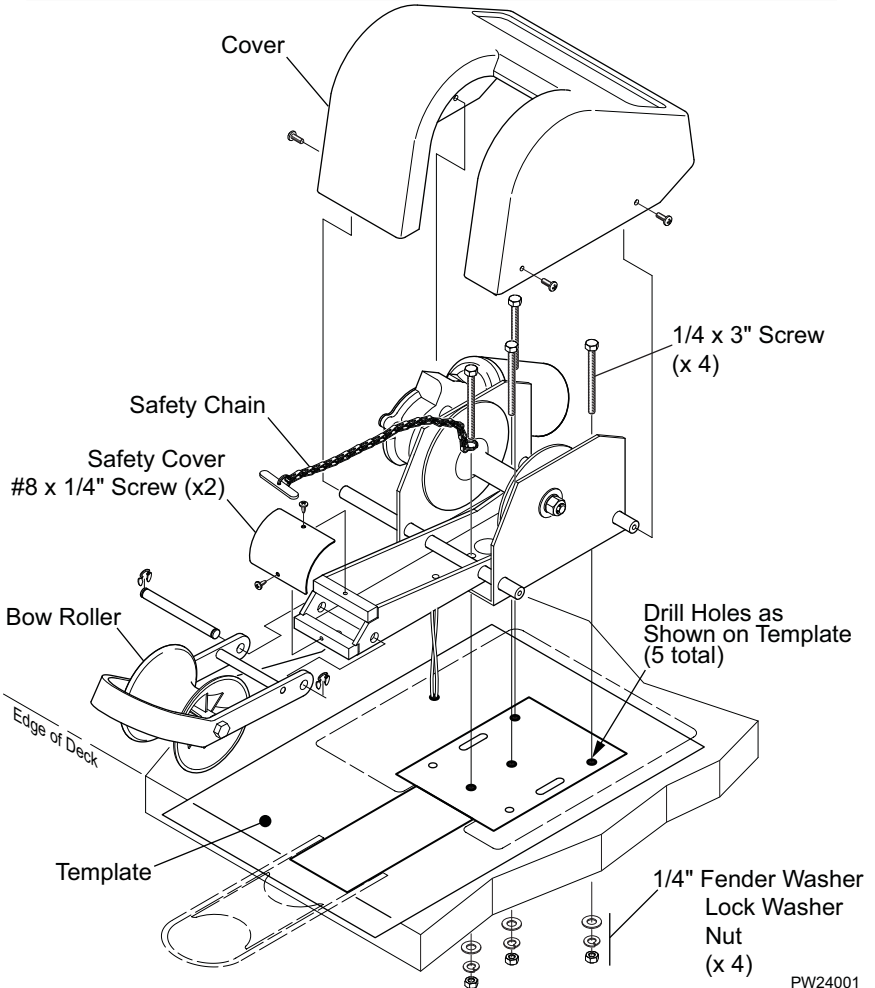
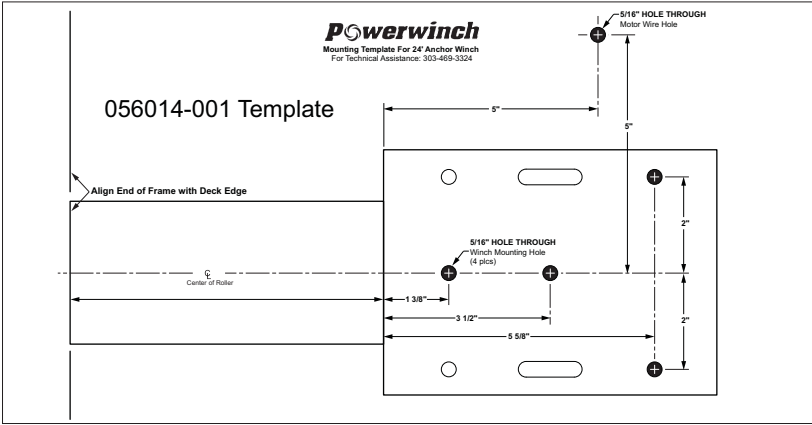

PW24001

1. If not previously done, remove the 4 screws and cover and set aside.
2. Place the mounting template on the deck in the desired location and secure with tape.
 - 2.1. The winch may be mounted on the fore (front) or aft (rear) of the boat.
 - 2.2. When mounted, the roller assembly must extend past the deck to allow anchor to clear the deck when retrieving or when the anchor is docked in the roller.
3. Drill the holes as marked on the template.
4. Remove the template.
5. Assemble the safety chain.
 - 5.1. Place one split ring at one end of the chain.
 - 5.2. Attach the safety bar to the other end of the chain using a split ring.

NOTE: It may be necessary to remove links after the anchor has been attached and drawn up. The chain should be tight when attached to the anchor.
6. Place a bead of silicone sealant around the base of the winch and the around the newly drilled mounting holes.
7. Set the anchor on the deck and align the holes in the frame with the holes drilled in the deck.
8. Secure the winch to the deck using four (4) each of 1/4 x 3" bolt, fender washer, lock washer and nut. On the forward bolt, slide the bolt through the open split ring of the safety chain then slide the bolt through the frame and deck hole.
9. Attach the davit roller assembly to the frame as shown.
10. Attach the safety cover using two (2) #8 x 1/4" pan head screws.

WIRING THE UNIT

WARNING ALWAYS disconnect the battery before working on electrical equipment.

WARNING ALWAYS use the recommended wire size and rated circuit breakers. Failure to use the furnished and recommended sizes can cause a fire hazard and void warranty.

NOTICE When routing the wiring, avoid sources of heat.

NOTICE When routing the wiring, avoid sharp edges that can cut or fray the wire insulation.

- Determine the switch location. Ensure that there is adequate room behind the mounting surface for the switch and wiring.
- Drill a 1/2" hole through the mounting surface.
- Center the label over the hole, remove the release paper and attach.
- Route one RED and one BLACK 12 awg wire from the anchor to the switch location. Be sure to allow adequate wiring to make connections, allow the wire to have some slack when routing. Secure the wires with wire ties.
- At the winch, attach the new wires to the motor wires using the butt connectors. Ensure that the crimps are solid and that the wires cannot come loose.

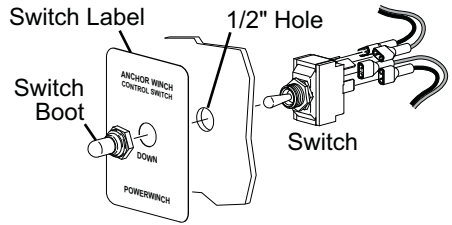

PW24002a

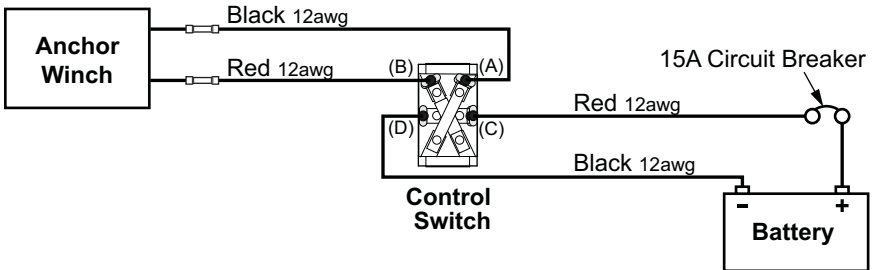

PW24003

- At the switch position, terminate wire with a 12awg 1/4" female disconnect. Ensure that the crimp is solid and cannot pull off.
- Connect the wires to the switch. The RED wire goes to terminal "B" and the BLACK wire goes to terminal "A".
- Route one RED and one BLACK 12 awg wire from the switch to the battery location. Be sure to allow adequate wiring to make connections, allow the wire to have some slack when routing. Secure the wires with wire ties.
- At the switch position, terminate wire with a 12awg 1/4" female disconnect. Ensure that the crimp is solid and cannot pull off.
- Connect the wires to the switch. The RED wire goes to terminal "C" and the BLACK wire goes to terminal "D".

11. Push the switch through the switch mounting hole. Secure the switch with the switch boot.
12. At the battery, terminate the BLACK wire with a 5/16 ring terminal. Connect wire to the negative post of the battery.
13. Terminate the RED wire with a #10 ring terminal. Attach the wire to the 15A circuit breaker on the post opposite the buss bar.
14. Attach the circuit breaker to the positive (+) post of the battery.

TESTING THE UNIT

1. Ensure that all connections are secure and correct.
2. Without rope, press and hold switch in upward position. If wiring to switch terminals is correct, the spool will spin counterclockwise (toward the rear of the winch).
If the motor runs in the wrong direction, switch is incorrectly wired. To correct, switch the anchor red and black wires on back of the switch.

LOADING THE ROPE

1. Feed rope through davit or bow roller and pull toward anchor winch. Make sure rope is not twisted or kinked and can freely run through bow roller or davit.
2. Insert the rope through the hole located in the side of the drum (from the side opposite of the countersunk hole).
3. Feed enough rope through to tie an overhand knot at the end of the rope.
4. Pull the rope back until the knot is seated in the countersunk opening.
5. Keep tension on the rope and feed the rope on the drum by running the anchor winch with the switch in the up position. Correct rotation is essential for proper operation. The rope must feed from the top of the drum.
6. Install the cover onto the winch.

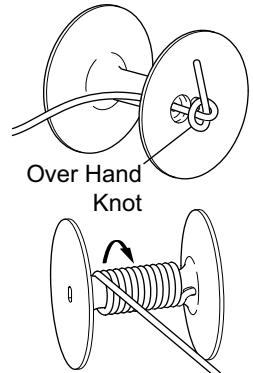

Over Hand Knot

PW24004

ATTACHING THE ANCHOR

Use a river, mushroom or navy type anchor up to a maximum weight of 40 lbs.

NOTICE

Do not exceed the 40lb maximum weight rating of the winch. The winch will not operate correctly if the anchor is too heavy.

1. Tie an appropriate sized anchor shackle (not included) to the end of the rope. Test that the knot will not slip or come apart.
2. Attach the shackle to the anchor.

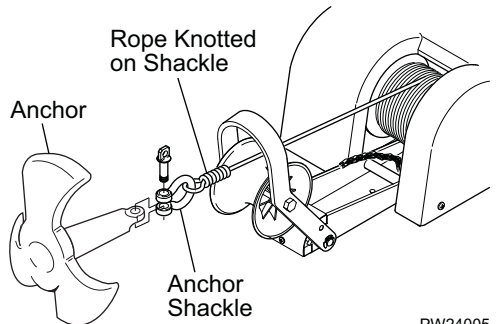

PW24005

OPERATING THE WINCH

The anchor winch is simple to operate.

To Lower: Press the switch in the down position to lower the anchor.

To Raise: Press the switch in the up position.

NOTICE Do not pull the boat to the anchor point with the anchor winch. This can cause damage to the winch motor. Always use the boat motor to move toward the anchor point.

SAFETY CHAIN

The safety chain is designed to hold the anchor in place when the anchor winch is not in use. The safety chain is used when the anchor is in the UP position.

WARNING Always attach the safety chain when the anchor is in the up position. If the anchor should break loose when the boat is cruising or being trailered, severe damage and/or injury can occur.

To attach the safety chain, slide the safety bar through the shackle.

Note: The chain should fit tightly to securely hold the anchor. Remove chain links as necessary.

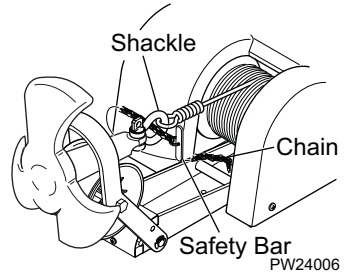

MAINTENANCE

Following each boat outing, flush exterior of winch with fresh water. Use only mild detergents to clean exterior. Use of solvents can cause damage to the finishes and seals, as well as void product warranty

Check electrical connections every 6 months for corrosion. Replace any connection or wire which is damaged, corroded, frayed or worn.

Check rope periodically for abrasion or deep cuts. Never splice an old rope with a new rope. If replacement is necessary, use only Powerwinch® rope specifically designed for this product.

TROUBLESHOOTING GUIDE

WINCH DOES NOT OPERATE			
A.	Confirm power to winch		Correct as required.
	1. Check battery is fully charged 2. Confirm connections are tight & clean. 3. Check wires are worn or bare that may cause shorts		
B.	Check circuit breaker at battery		
	Bypass circuit breaker and test winch. Does the winch run?	YES	If winch runs, circuit breaker is bad, replace.
	NOTICE Do not operate the winch without the circuit breaker. Removing the CB from the circuit is ONLY for testing.	NO	Reconnect circuit breaker and go to step C.
C.			
	Anchor is too heavy	Correct as required.	
	The maximum anchor weight for this winch is 40 lbs.		

REPLACEMENT PARTS LIST

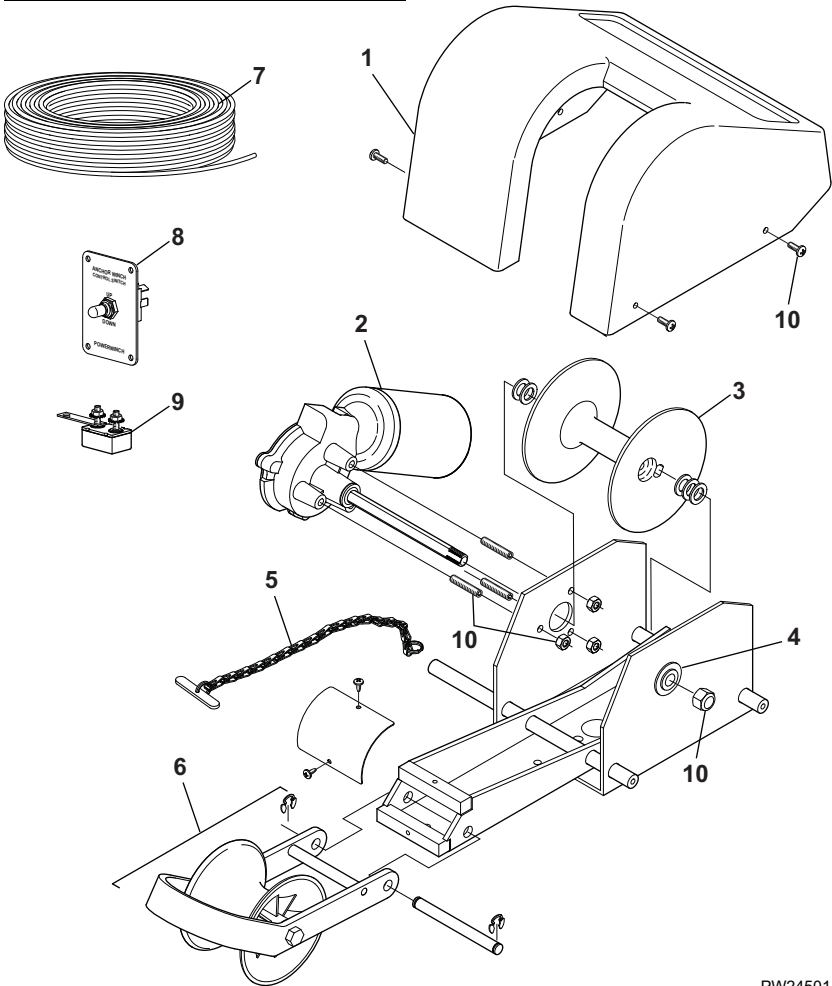

PW24501

Item	Description	Description	Notes
1	R001418	Cover Kit	
2	R001417	Motor Kit	
3	R001421	Rope Spool	
4	R001425	Bearing	
5	R001423	Safety Chain Kit	
6	R001426	Bow Roller Kit	
7	P2210700AJ	Rope, Nylon, 3/16" x 100'	
8	R001419	Switch Kit	
9	R001422	Circuit Breaker Kit, 15amp	
10	R001424	Fastener Kit	

WARRANTY

Carefree of Colorado (hereafter referred to as Carefree) warrants to the FIRST retail Purchaser that the Powerwinch Product described in this manual is free of defects in material and workmanship within the terms and conditions as set forth below. Carefree's obligation under this warranty is limited to the repair or replacement, at Carefree's option, of any defective component within the stated warranty period. THIS WARRANTY IS NOT TRANSFERABLE.

1. DURATION

- a) 2 years on parts and labor.
- b) Carefree will pay the transportation charges for return shipment to the purchaser of any product received for legitimate warranty repair.

Warranty duration is not extended by the length of time the product is not in use or the time that the purchaser is deprived the use of the product. The duration of coverage is determined by the date of the original product purchase, not the date of repairs.

2. WHAT IS COVERED UNDER THIS WARRANTY

Defects in the manufacturer's material and workmanship of product under normal use, and which occur within the duration of the warranty period.

3. WHAT IS NOT COVERED UNDER THIS WARRANTY

- a) Improper installation and/or any consequent damage or failure that results from improper installation of the product.
- b) Normal wear.
- c) Conditions that are not related to the material or workmanship of the product: including any failure that results from an accident, wind, rain, or other acts of God.
- d) Purchaser's abuse, including but not limited to neglect; failure to operate, use or maintain the product in accordance with the instructions provided with the product.
- e) Any component not sold or manufactured by Carefree.
- f) Any failure that results from the use of another manufacturer's product with a Carefree product that is not specifically approved by Carefree.
- g) Any incidental, indirect, or consequential loss, damage or expense that may result from any defect, failure or malfunction of the product.
- h) The removal or alteration of any product component or device. In the event of such removal or alteration, this warranty is void.
- i) Any expense related to delivery or pick-up of product to/from the service dealer.

4. RESPONSIBILITIES OF THE PURCHASER

IN ORDER FOR THE WARRANTY TO BE HONORED, THE PURCHASER MUST HAVE PROOF OF PURCHASE. FAILURE TO PROVIDE THE REQUIRED DOCUMENTATION MAY DELAY OR VOID ANY WARRANTY CLAIM.

- a) Retain dated proof of purchase for the product, and provide it as requested.
- b) Perform "Periodic Maintenance" as specified in Owners Manual.
- c) Use reasonable care in maintenance, operation, use and storage of the product in accordance with the instructions contained in the owner's manual.

THIS WARRANTY GIVES THE OWNER SPECIFIC LEGAL RIGHTS. THE LAWS OF CERTAIN JURISDICTIONS MAY GRANT THE OWNER ADDITIONAL RIGHTS AND PRIVILEGES. Except as set forth above; Carefree makes no warranty, whether statutory or otherwise, including without limitation, any warranty of merchantability or fitness for a particular purpose. Carefree shall have no liability except to repair, replace or adjust defective products and parts. Carefree specifically excludes any liability, whether in contract, tort or otherwise, for personal injury, property damage, economic or consequential losses. Carefree has not authorized any person or company to alter the terms of this warranty.

It is Carefree of Colorado's policy and practice to continuously improve the company's products and services. Therefore, Carefree reserves the right to make changes in design and components, without notice, whenever it is believed the quality of the product will be improved, but without incurring any obligation to incorporate such improvements in any product which has been shipped or in service.

